

Dismantling a Burman gearbox

Fitted to many British and Continental machines, Burman gearboxes will provide trouble-free service if correctly maintained

All internal parts of the four-speed Burman type C or BA gearbox can be removed without difficulty if the correct procedure is followed, but the job should not be undertaken lightly unless you have some knowledge of mechanics.

For the purpose of description it is convenient to start with the clutch, though, if need be, the gear parts can be stripped without disturbing the clutch as a unit. In certain cases a covering band is fitted over the clutch box, and this is the first item to be removed. Next, the clutch spring adjusting nuts should be unscrewed, after which the springs, spring cups and pressure plate can be withdrawn.

The clutch plates can now be lifted out. It is important to remember that they must be retained and replaced in the correct order. The nut which holds the clutch body to the mainshaft has a right-hand thread and after its removal the clutch body can be withdrawn from the splined shaft.

This process exposes the roller race on which the clutch sprocket rotates and also the rubber shock absorbers, so that these parts may now receive attention if necessary. Do not dismantle the roller race unless this is essential, since the replacement of the rollers can be tiresome.

When tackling the gearbox it is necessary first of all to detach the clutch cable. In some of the later boxes the clutch lever is concealed within the outer cover plate, and the large screw plug situated over the upper end of the lever must be removed before the cable end can be reached.

Next, the nuts holding the outer cover can

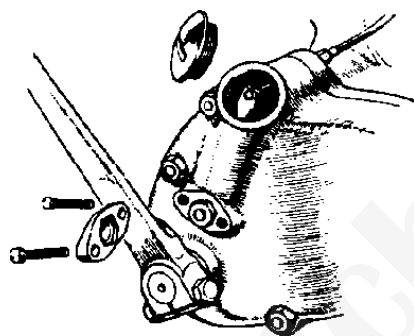

Some of the later Burman gear boxes have an internal clutch lever. The cable can be detached after removing the screwed cap; the adjusting nut has a locking cover plate retained by two screws. To take up clearance the nut should be turned anti-clockwise.

be unscrewed and the cover itself withdrawn. This job may require a little jiggling, but the joint may be broken by the judicious use of a soft faced hammer or a wooden mallet, and then the kickstarter and gear control pedals form convenient handles for withdrawal.

The kickstarter quadrant and spring will come away with the coverplate as a complete unit, and unless due precautions are taken the whole foot control mechanism will also come away.

If this should happen no harm is done, as the teeth of both quadrant and pinion are marked for correct engagement. If, however, the

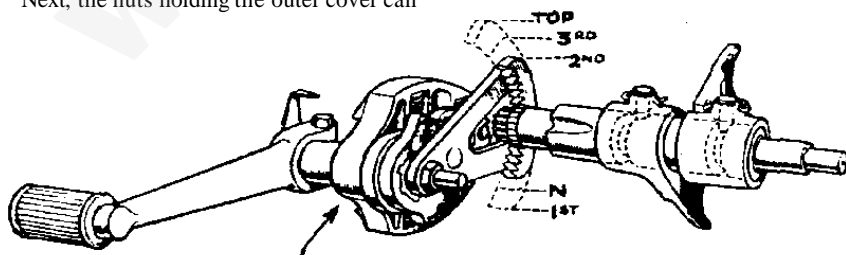

The foot-change mechanism with the cam spindle and gear operating forks. The action is explained diagrammatically overleaf.

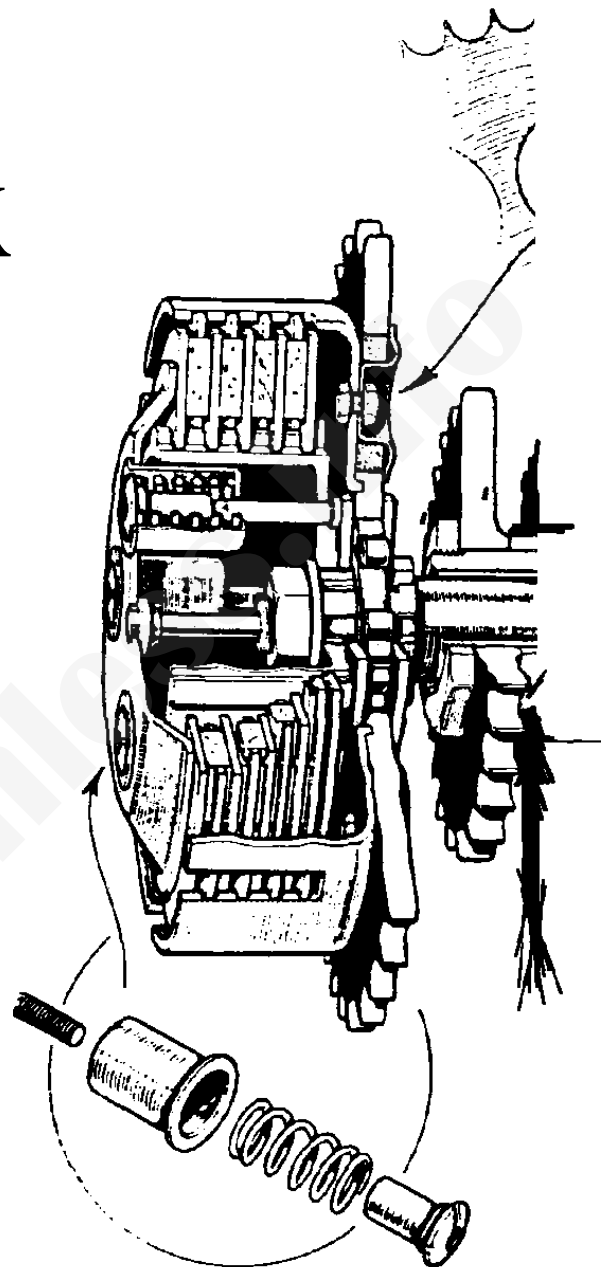

whole of the gears are not to be stripped, it may save trouble if the nut which holds the neutral indicator is removed and the central spindle is pressed inwards as the cover is withdrawn. This will leave the quadrant in mesh with the pinion, and the actual teeth which are meshing at the time of withdrawal can be marked.

When the internal type of clutch lever is fitted, the next job will be to withdraw the short forked clutch thrust rod and then the steel ball which lies within the mainshaft.

It is now possible to examine the foot operating mechanism and though the operation of this item is difficult to describe, the parts are quite simple and dismantling is straightforward.

The quadrant and its spindle can be withdrawn, as already explained, and after this the double-acting pawl can be lifted off. Then, after removing the pedal from its serrated

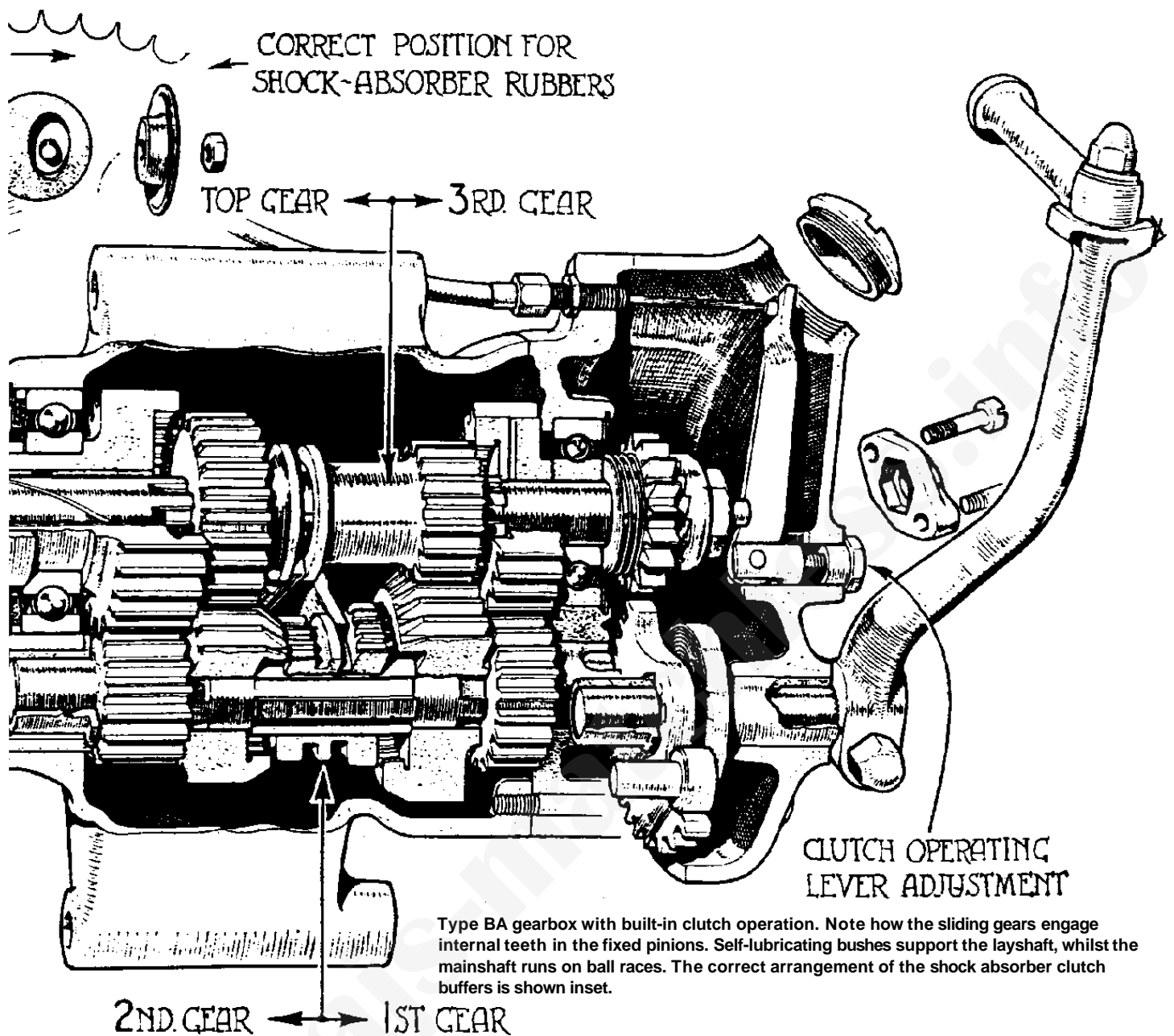

Type BA gearbox with built-in clutch operation. Note how the sliding gears engage internal teeth in the fixed pinions. Self-lubricating bushes support the layshaft, whilst the mainshaft runs on ball races. The correct arrangement of the shock absorber clutch buffers is shown inset.

shaft, the pawl plate and the spring box can be removed either singly or as a unit.

There should be no difficulty in re-entering the pins between the springs as the spring ends are prevented from closing together when the pins are withdrawn by thrust plates which rest on ledges, thus leaving a comfortable clearance for the pins to enter.

If you need to dismantle the box further, it is necessary to remove the nut on the mainshaft (right-hand thread) and the nuts which retain the inner cover plate. The outer end of the cam spindle is carried on an uncaged roller race and when removing the inner cover plate the loose rollers may drop out. Collect them carefully; there are 12 in all. When reassembling they may be held in position by grease. Before attempting to withdraw the gears, unscrew the plug at the bottom of the gearbox and take out the spring for the pawl which locates the gears within the box.

After this has been done the whole gear assembly, including the camshafts and striking forks, can be withdrawn as a unit though the process may be rendered more easy by first withdrawing the mainshaft from the opposite end of the box. This leaves only the final drive gear and sprocket in the box and it is seldom that they need to be dismantled.

If, however, the bearing on which they run shows signs of wear, indicated by side play, they can be separated as follows: The sprocket must be gripped to prevent rotation, and the best method is to wrap a length of chain round the teeth and to hold both ends of the chain in a vice. The jaws of the vice should, of course, grip the chain close up to the sprocket. Use an old chain if possible, but if there is no other alternative a sound chain may be employed, provided that it is protected by soft jaws.

The lock nut, which must now be unscrewed, is large and parts of its inner

periphery are punched into splines on the shaft to prevent it from unscrewing. Because of this it is likely to be useless a second time unless you take great care.

If a gear striking fork requires renewal, the fork can be removed from the camshaft after withdrawing a split pin which locates the retaining pin and then pulling out the retaining pin itself with pliers.

There are two of these aluminium-bronze striking forks and they are not identical, therefore, when ordering a new one be careful to state whether it is for the mainshaft or layshaft gears.

When reassembling the box it is best to feed in the camshaft with its forks and gears as a unit and to feel the mainshaft into position afterwards. Before replacing the outer cover plate, make quite sure that you have timed the operating mechanism by assembling the quadrant and pinion to their correct marks.

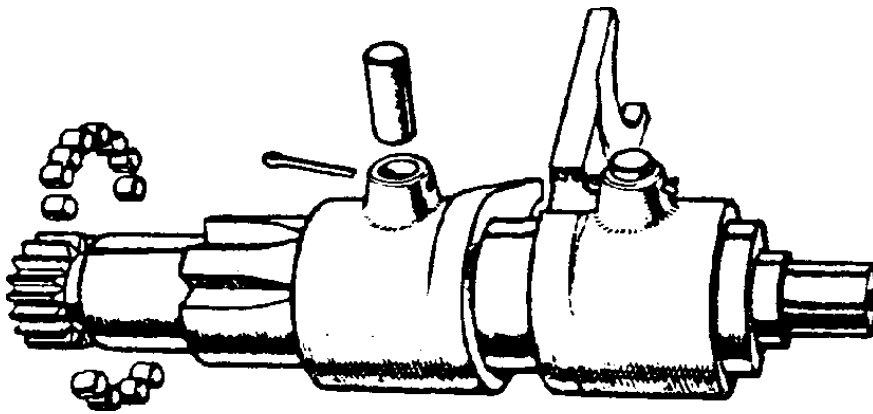

THE SHOCK ABSORBER

If the chain wheel can be moved relative to the clutch drum the shock absorber rubbers should be replaced. If, however, there is no relative motion between the parts, but both together can be tilted sideways, wear in the clutch race is indicated and new rollers should be fitted.

Should the clutch spring retaining nuts show a tendency to unscrew of their own accord, they should be removed and both nuts and springs carefully cleaned. Afterwards the spring ends and their abutments should be polished with emery cloth and all parts lightly greased before reassembly.

The control end of the camshaft is carried on an uncaged roller bearing; during reassembly the 12 rollers can be held in place by grease. The striking forks are with drawn from the camshaft after the removal of a split-pin and the pulling out of a peg.

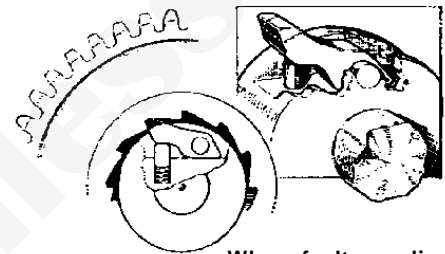
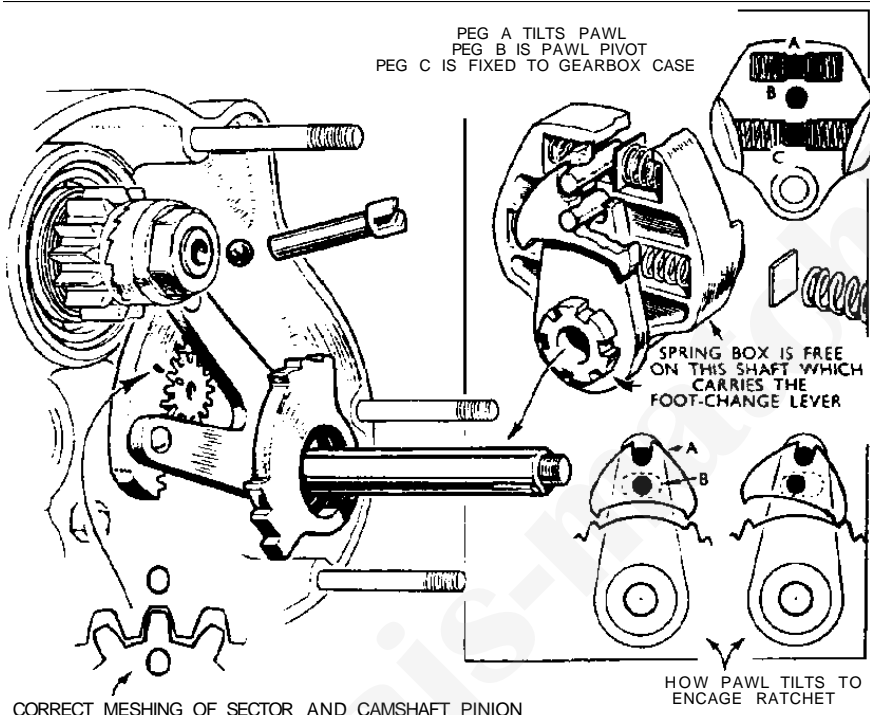

Where faults may lie in the kick-starter mechanism.

- Operation of the foot-change. Note the marking of the quadrant and its pinion, and how the pawl is tilted to engage with the sector. The mechanism is centred by peg C and its two springs.

CORRECT MESHING OF SECTOR AND CAMSHAFT PINION

PARTS SUPPLIERS

(Where a firm specialises in particular marques only, this is noted after their phone number).

G Brewer Motorcycles
(0424 443093). Panther.

Draganfly Motorcycles
(0986 894798). Ariel.

Joe Francis Motors
(081 850 1373). AJS and Matchless.

Hamrax Motors
(081 969 5380). AJS & Matchless.

Nigel Mackenzie
(081 789 2411 eves). Ariel.

Russell Motors
(071 228 17 14). AJS & Matchless.

The AJS & Matchless, Ariel and Panther Owners clubs run spares schemes that stock Burman parts to fit their marques, available to members only.

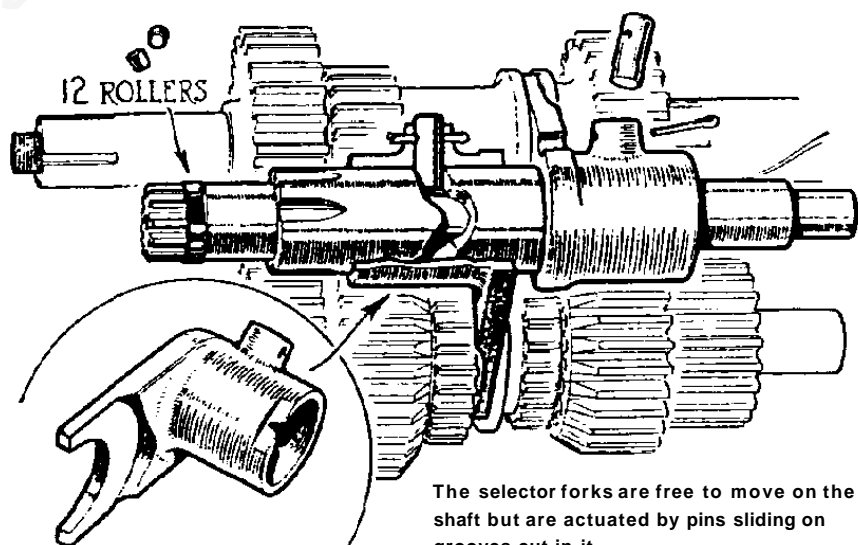

The selector forks are free to move on the shaft but are actuated by pins sliding on grooves cut in it.

BURMAN GEARBOX TROUBLESHOOTER

The most frequent of the few causes of gearbox trouble is that of gears jumping out of mesh.

In the Burman box, there is more than one possible cause for the complaint. If only top gear is affected it is likely that the ball bearing which carries the final drive gear and sprocket has become worn, thus allowing the gear to tilt and gradually wriggle out of engagement.

The jumping of other gears may be caused by wear in the ratchet or pawl of the foot control mechanism with the consequence that the gear is never fully engaged, or it may be due to wear of an operating fork.

Other possible causes are wear of the engagement dogs (only likely after very long use) and a weak spring below the pawl which locks the operating mechanism inside the box. The remedy is obvious in each case, since the worn part must be replaced. There is a point to be remembered when the pawl spring is replaced, for if too strong a spring is used the gears will be stiff and hard to operate; therefore, it is desirable that only a correct spring should be fitted.

Should the kickstarter show a tendency to jamming it is almost certainly due to the sharp edge of the ratchet pinion teeth becoming worn. These teeth can be filed to an edge once more and, if worn, the first tooth of the quadrant can be filed to give a suitable lead.

LUBRICATION

Stiffness in operation is most commonly due to the use of an incorrect grade of grease, where this is the lubricant specified. The box should be maintained about one third full. Besides causing stiff operation, heavy grease has a further disadvantage since it is apt to be thrown on the inside walls of the box away from the gears and consequently fail to return fast enough to provide adequate lubrication. Use Castrol LM grease or similar. For fast touring, the greases may be thinned out by the addition of about 25 per cent of engine oil.

Post-war, oil (SAE50 or EP90) was the recommended lubricant For AJS and Matchless

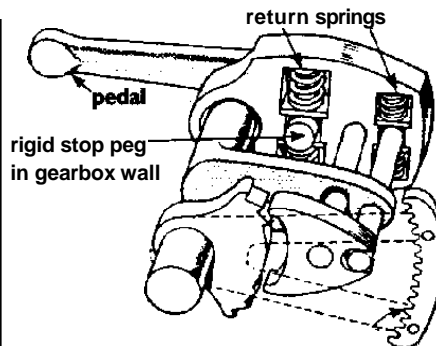

A rack attached to the ratchet sector engages with the cam spindle.

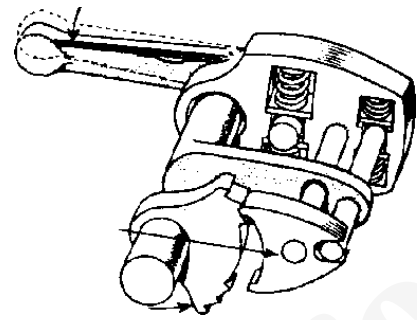

The initial movement of the pedal, either up or down, tilts the pawl which then engages the ratchet sector.

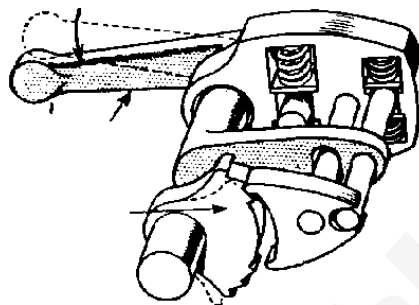

The complete movement of the pedal has moved the ratchet sector and engaged a gear.

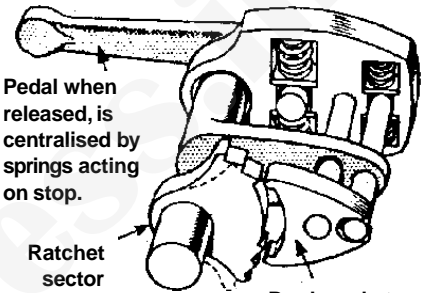

Pedal when released, is centralised by springs acting on stop. Ratchet sector remains in position. Pawl ready to engage next notch in ratchet.

A. These four diagrams show the complete cycle of operations that occurs when the foot-change lever is depressed.

machines, for instance, the changeover from grease to oil took place on 1948 models.

The mainshaft is fitted with a seal to prevent this leaking out. A level plug is fitted.

CLUTCH SLIP

In the case of clutch slip the first thing to do is to examine the clearance ($\frac{1}{32}$ in) between the clutch rod and the clutch lever. If there is too little clearance, first make sure that the clutch cable is working freely in its casing before adjusting the clutch lever or the cable stop.

Fabric clutches will slip if oil or water reaches the plates, and the only way to cure this is to dismantle the clutch and clean the plates. Take care to replace the plates in the correct order.

SPRING PRESSURE

Clutch springs may lose their temper if the clutch is constantly slipped, and weak springs should be replaced. The spring pressure is adjustable to some extent but the abutment stops must not be screwed right home or the clutch cannot be withdrawn. The adjustment is correct when the screw heads are flush with the end plate and all screws should be tightened to the same extent in order to prevent tilting of the pressure plate.

A stretched control cable, incorrect adjustment of the clutch controls, or grooves worn in the slots of the clutch drum by the edges of the plates will mean that the clutch fails to withdraw cleanly.

Grooves in the clutch drum slots are caused, primarily, by wear in the roller race supporting the chain wheel, which allows the clutch drum to tilt, and rub against the plates. A new race will probably cure the trouble, but if the wear is bad new plates may also be required. The slots in the clutch drum must be dressed with a file to give a square edge.

Where the clutch runs in an oil bath, drag may be caused by the use of incorrect oil. It may be necessary to dismantle and clean the plates. SAE 30 oil is thick enough, but if the chaincase does not get hot, water condensation may turn the oil into an emulsion. Car gearbox automatic transmission fluid (ATF) is much better, especially with cork lined clutches. Drain out the old oil and replace with ATF. Castor oil should never be used in the oil bath.

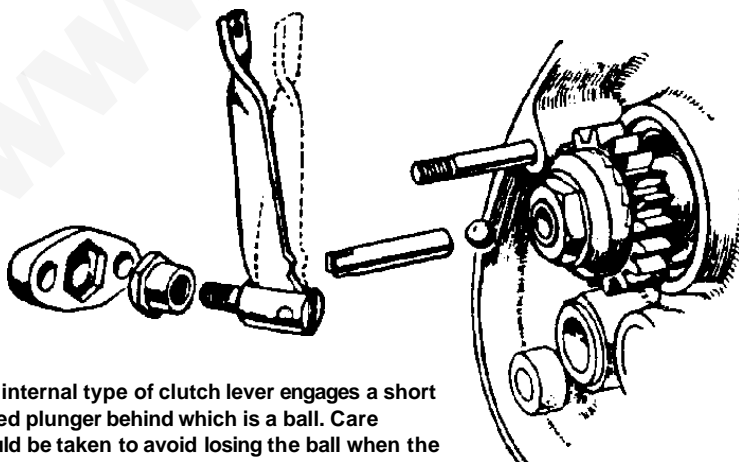

The internal type of clutch lever engages a short forked plunger behind which is a ball. Care should be taken to avoid losing the ball when the gearbox is being stripped.